

HEADLIGHT VSL HUSQVARNA

MASCHERINA VSL HUSQVARNA

ACERBIS

COD. 500006169 REV.2

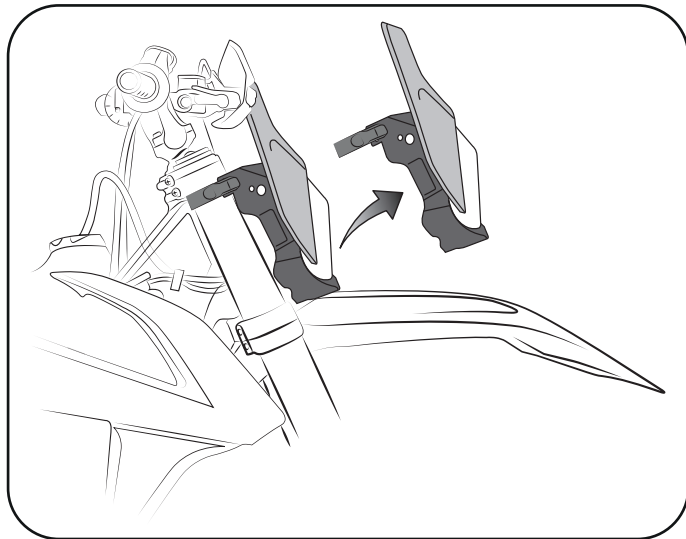
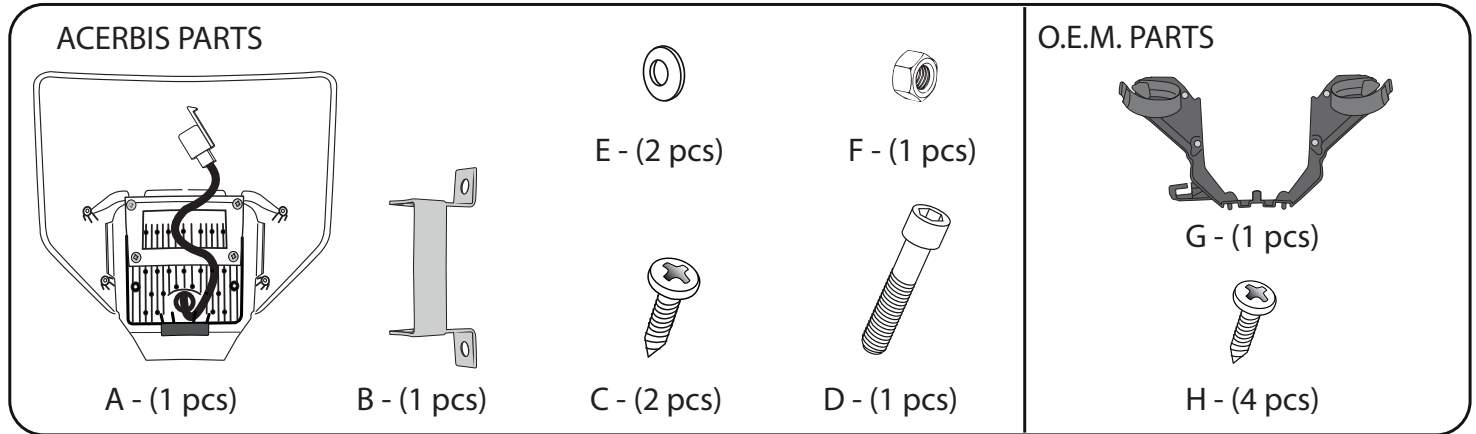

1 - Remove the original headlight mask from the bike.

1 - Rimuovere la mascherina originale.

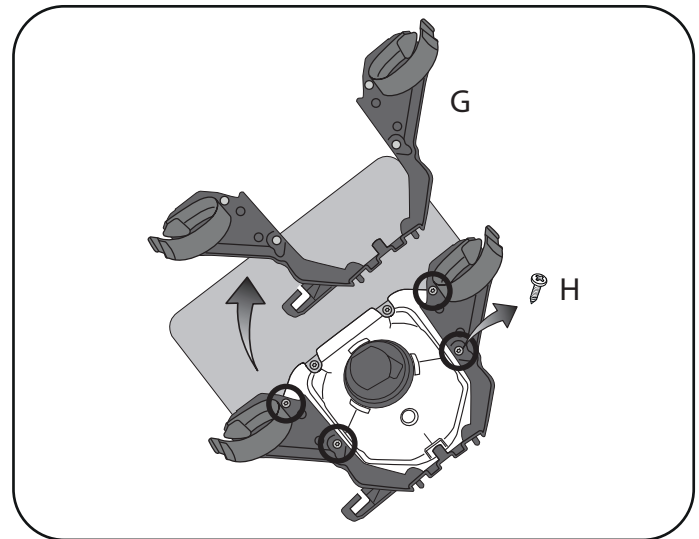

2 - Unscrew the 4 screws (H) and remove the frame (G) from the original headlight mask.

2 - Togliere le 4 viti (H) e rimuovere il telaio (G) dalla mascherina originale.

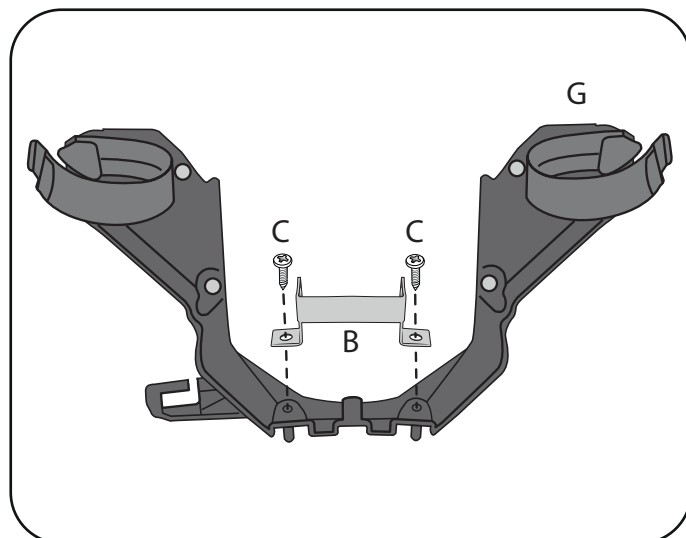

3 - Assemble the bracket (B) on the original frame (G) using the screws (C).

3 - Montare la staffa (B) al telaio originale (G) utilizzando le viti (C).

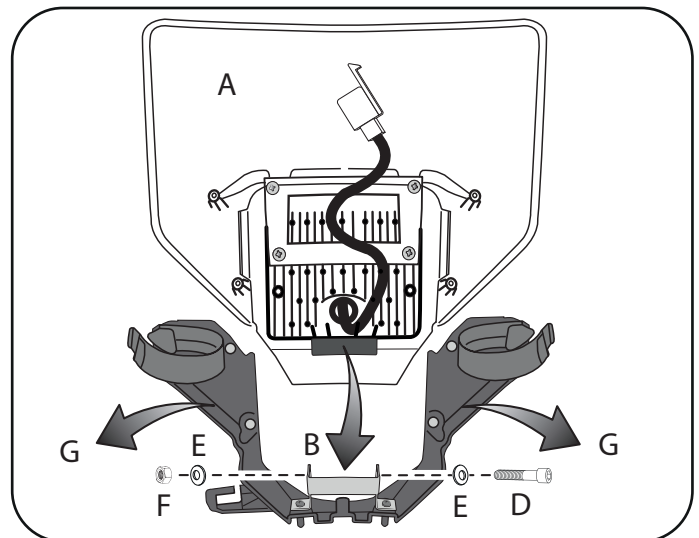

4 - Attach the ACERBIS Headlight (A) to the original frame by inserting the screws (D), the washers (E) and the nut (F) through the (B) bracket. Spread the frame slightly to help insert the (D) screw into the bracket (B).

4 - Inserire la mascherina ACERBIS (A) nella staffa (B) utilizzando la vite (D) le rondelle (E) e il dado (F). Per facilitare il montaggio della vite (D) allargare il telaio originale (G).

HEADLIGHT VSL HUSQVARNA MASCHERINA VSL HUSQVARNA

ACERBIS

COD. 500006169 REV.2

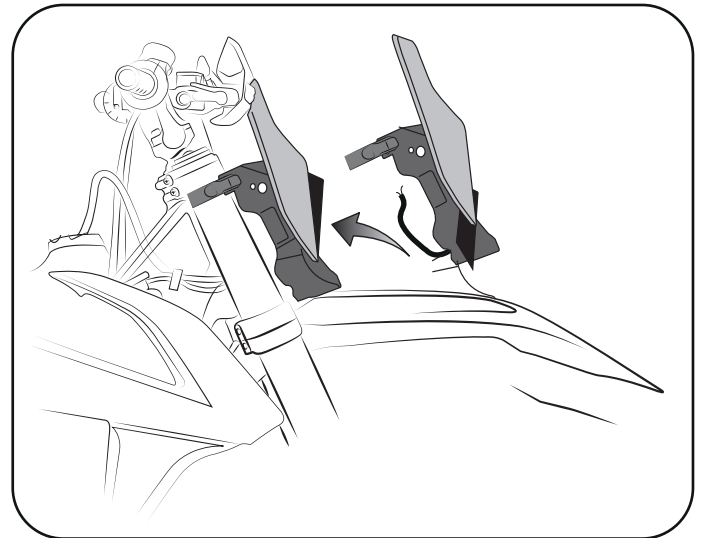
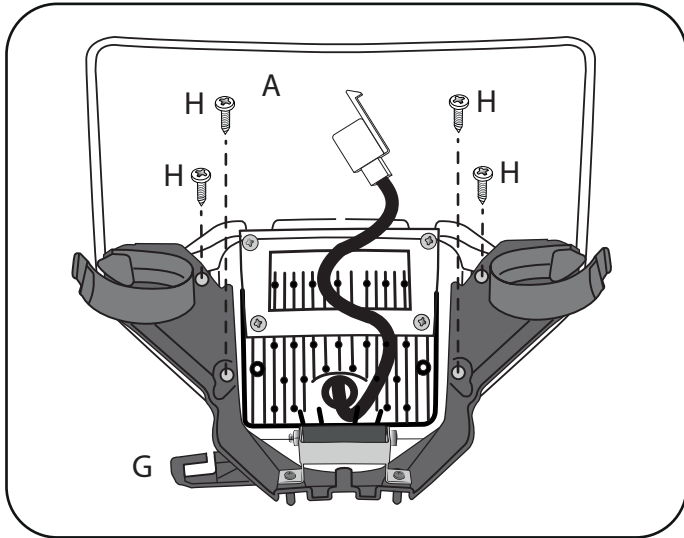

5 - Finish attaching the frame (G) to the headlight (A) using the 4 original screws (H).

5 - Fissare il telaio originale (G) alla tabella portanumero (A) utilizzando le 4 viti originali (H). Il telaio originale (G) deve premere la cornice in plastica nera. Bloccare la vite (D).

6 - Connect the power cables and attach to the bike using the original rubber mounting bands.

6 - Collegare i cavi.
Rimontare la mascherina ACERBIS utilizzando gli elastici originali.

**WARNING !
MAX 9 - 32 V DC**

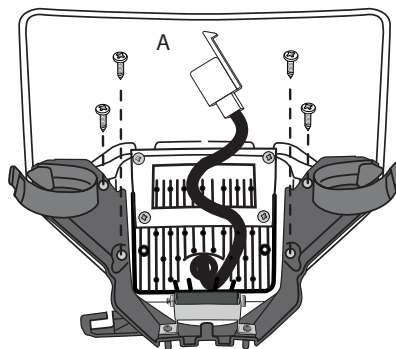

WARNING!

Use at your own risk. Check the security of your device before you ride. Be sure that you follow the instructions installing the Acerbis products. Do not ride if there is missing or damaged hardware. If this is the case, take the item immediately back to your dealer. Make sure the throttle and other controls are free every time you ride. Lack of attention to instruction and warning could lead to interference with the controls, loss of control, and an accidents. Acerbis recommends that installation must be done by a licensed mechanic and that only Acerbis original parts are used during fitting. Acerbis makes no guarantees or representations, express or implied, regarding the fitness of its products for any particular purpose. Acerbis makes no guarantees or representations, express or implied, regarding the extent to which its product protect individuals or property from injury or death or damage.

WARNING: In the event that the headlight is connected directly to the battery, once the motorcycle has been switched off, make sure the headlight is turned off. This is to prevent the battery from running down quickly.

ATTENZIONE: Nel caso in cui il faro venisse collegato direttamente alla batteria, una volta spenta la moto, anche il faro dovrà essere immediatamente spento. Questo per evitare che la batteria stessa si scarichi velocemente.

ACERBIS ITALIA S.P.A. VIA SERIO, 37 - 24021 ALBINO (BG) - ITALY

Phone +39 035773577 - Fax +39 035773570 - INFOMOTO@ACERBIS.IT - WWW.ACERBIS.COM

ACERBIS U.S.A. Inc.

MAIL P.O. BOX 2030 SUN VALLEY, ID 83353 SHIP 110 LINDSAY CIRCLE KETCHUM, ID 83340

Phone (800) 659-1440 - Fax (208) 726-7039 - INFOUSA@ACERBIS.COM

ACERBIS U.K. Ltd

UNIT 2 LUTON ENTERPRISE PARK SUNDON PARK ROAD LUTON, BEDFORDSHIRE LU3 3GU GREAT BRITAIN

Phone +44 1582491076 - Fax +44 1582499639 - UKINFO@ACERBIS.IT