

KTM SX 125/150/250 FUEL TANK 12 LT - GAL. 3,1

SERBATOIO 12 LT KTM SX 125/150/250

ACERBIS

COD. 500006176

ACERBIS PARTS

O.E.M ITEMS TO USE:

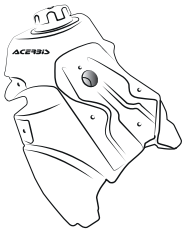

A - (1pcs)

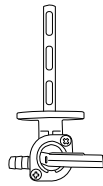

B - (1pcs)



C - (2pcs)



D - (1pcs)



E - (2pcs)



F - (4pcs)



G - (1pcs)

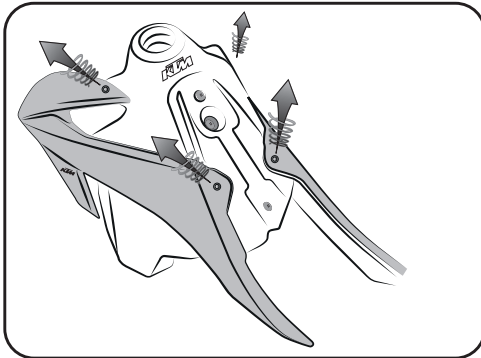

1 - Remove the radiator shrouds and seat from the original tank.
1- Rimuovere fianchetti e sella originale.

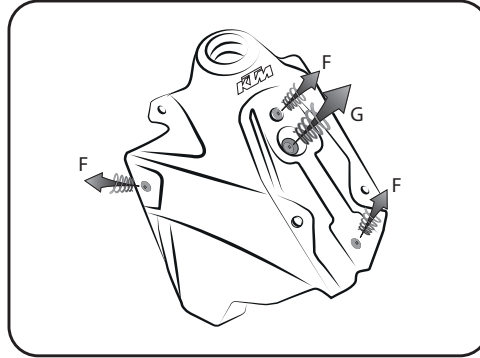

2 - Remove all remaining radiator (F) and seat (G) screws. Close the petcock and disconnect the fuel line from the carb. Remove the original tank.

2 - Togliere dal serbatoio originale le viti dei fianchetti e sella (F) e la vite del serbatoio (G). Chiudere il rubinetto benzina e staccare il tubo benzina. Rimuovere il serbatoio originale.

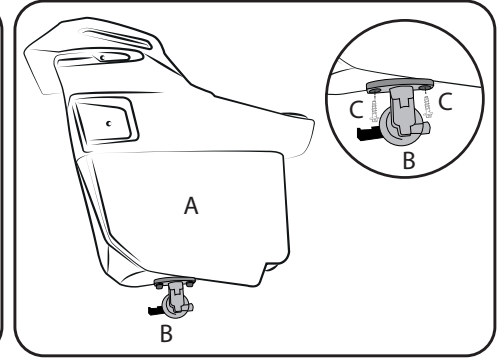

3 - Install the petcock (B) onto the Acerbis Fuel tank (A) using the supplied screws (C) as indicated in the image. Caution! The on/off lever is meant to face towards the bike to avoid accidental closure during use.
3 - Montare sul serbatoio Acerbis (A), il rubinetto (B) nella posizione indicata in figura, utilizzando le viti (C) in dotazione. (La leva del rubinetto è posizionata sul lato interno per evitare un'involontaria chiusura della benzina durante l'uso).

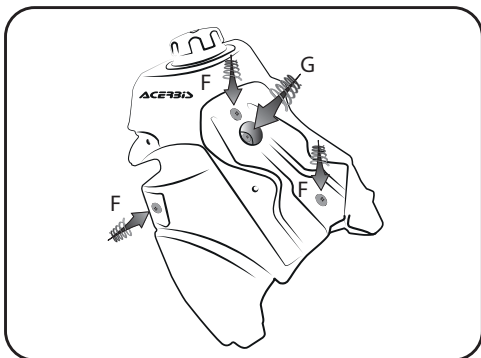

4 - Place the Acerbis fuel tank (A) on the bike. Install the original screws (F) and (G).
4 - Posizionare il serbatoio Acerbis (A) sulla moto. Riavvitare la vite del serbatoio (G) le viti della sella e dei fianchetti (F).

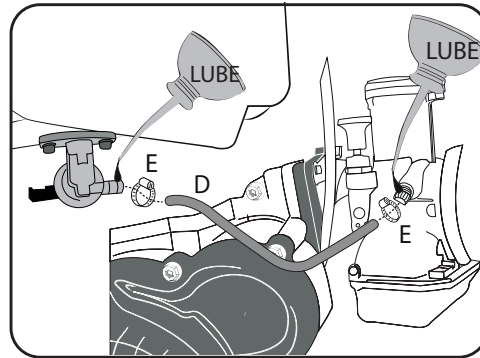

5 - Connect the Fuel line (D) to the petcock and carburetor. If needed use a small dab of 2 stroke oil/pre mix to lube the ends of the fuel line to help install. Tighten hose clamps (E) around the ends of the petcock and Carb.

5 - Collegare il tubo benzina (D) al rubinetto, utilizzando le fascette (E). Per facilitare il montaggio tubo/rubinetto utilizzare olio.

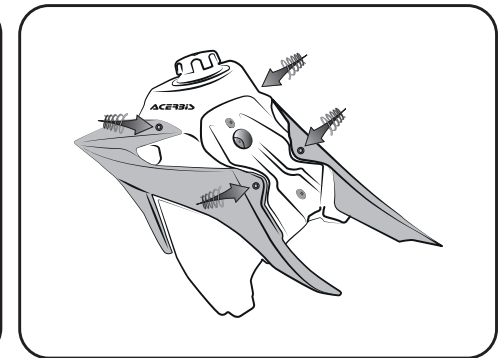

6 - Install the radiator shrouds and the seat.
6 - Rimontare i fianchetti e la sella originale.

LIBERATORIA

LIBERATORIA: A causa di variabili inponderabili nel processo di stampaggio rotazionale dei serbatoi, questi possono differire in forma e dimensioni fino al 7% rispetto alla capacità dichiarata.

**FOR COMPETITION USE ONLY
SOLO PER USO AGONISTICO**

ACERBIS

Thank you for purchasing an ACERBIS fuel tank

WARNING

It is **EXTREMELY IMPORTANT** that the fuel tank be properly installed. To ensure proper installation, it is **STRONGLY RECOMMENDED** that the tank be installed only by a qualified OEM licensed dealership mechanic. Improper installation could result in serious injury or even death.

If self-installed NOTE THE FOLLOWING. Particular attention must be paid to excessive fuel line length and fuel line proximity to hot engine areas and pipes to prevent fire.

Clean tank interior thoroughly before installation. Install this fuel tank only in a well ventilated area, as gasoline fumes are extremely dangerous. Do not start or operate the vehicle if there are any fuel leaks! Read all instruction first before beginning installation.

DISCLAIMER

Due to uncontrolled variables in the manufacturing process of rotationally molded fuel tanks, the fuel tank may vary in size and shape by up to 7% of the manufacturer's original listed capacity.